

Features

- ✧ Addressable Smoke Detector
- ✧ Advanced embedded MCU
- ✧ Drift compensation makes it environment adaptable
- ✧ 360° visible LED driven by Control panel
- ✧ Manually addressing via a dedicated hand held programmer
- ✧ Designed to comply with EN 54-7



Description

VG-6627 Digital smoke detector can compensate the variation of environmental parameters and judge fire alarms through algorithm fixed inside the excellent MCU, and send current operating state, smoke concentration, environment parameter etc. to control panel via digital signals transmission. With the pleasing appearance, it is easy to install and maintain. The detector is suitable for hotels, restaurants, computer rooms, banks, malls, warehouses, libraries, museums, offices and places with heavy moistures among the air. Besides, it is also applicable for places where black smokes occurred when there is fire.

Technical data

Operating Voltage:	16-28V(Modulated-pulse)
Standby Current:	≤0.5mA
Alarm Current:	≤1.0 mA
Wiring	Two-wire (non-polarized)
Temperature range:	-10℃~50℃
Humidity:	≤95%RH, (40±2℃) No condensation
LED Alarm Indication:	Red light emitting
LED Polling Indication:	Red light flashing
IP Rating:	32

Installation

- ✧ **Dimensions: Showing on Fig.1**

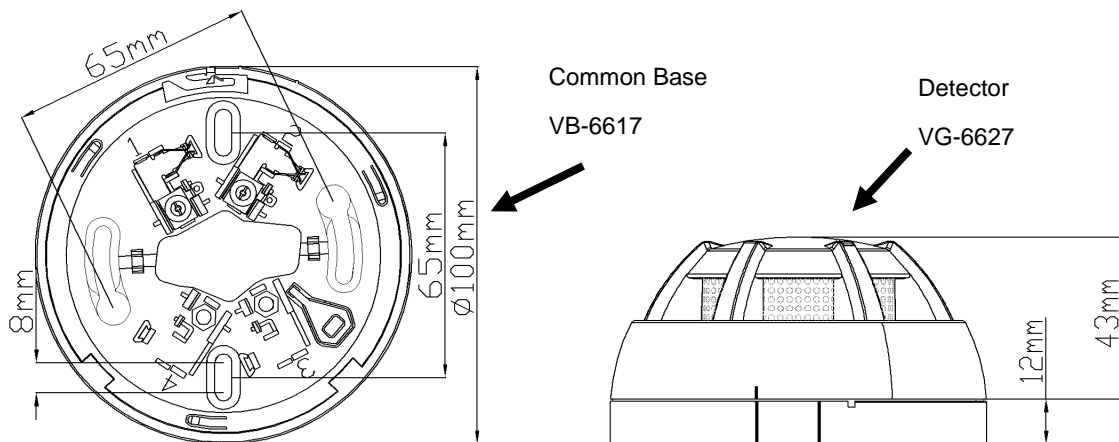

Fig.1 Dimensions

- ✧ **Mounting:**

Warning: Please disconnect the loop power in order to avoid control panel broken by short circuit when mounting Common Base.

Detector Head Mounting showing in Fig.2

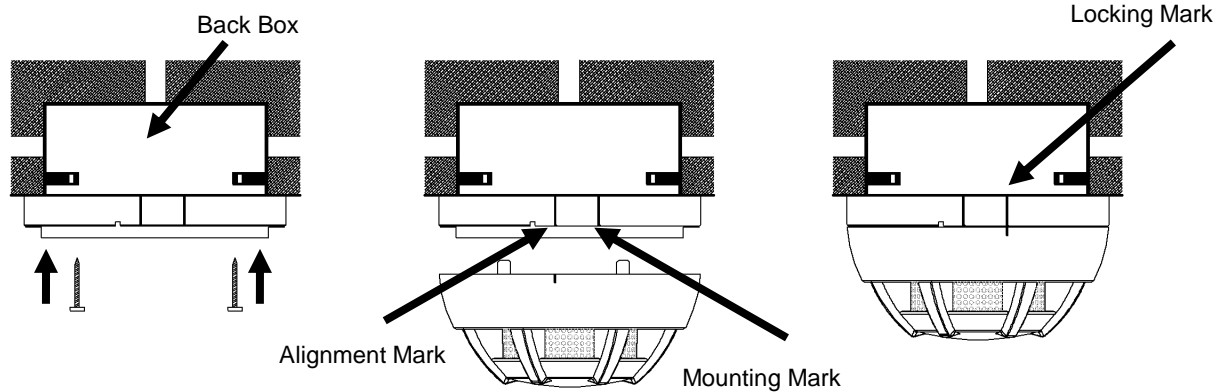

Fig.2 Mounting

◇ **Mounting Step**

1. Install the Common Base into Back Box which had installed in the wall by using screw. (Back box is standard 86H50 box) Make sure the Common Base installed stable.
2. Connect the loop to Common Base Terminal 1,2.
3. Install the detector head on to Common Base and direct Alignment Mark to Mounting Mark at same time.
4. Turn Alignment Mark aim to Locking Mark finish the installation.

Wiring Details

1. Wiring Requirement: RVS-2*1.0 mm² or 1.5 mm² wire for BUS, laid through metal tube (cable sink) or PVC tube.
2. 1,2 Should connecting with fire alarm system detection loop (Non-polarized)
3. Loop wiring is shown in Fig.3

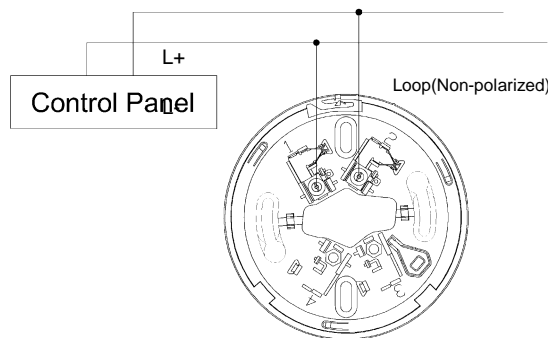

Fig.3. Loop wiring

Address setting

1. VG-6532 Digital Programmer is used to write an address of the Detector. Connecting Programmer with loop terminals: 1,2 of the Detector before it installation .
2. Set address , Pressing Write key, the address will be shown on the numeric display if successful. It is fail if there is no address. Please refer to VG-6532 Digital Programmer Manual for details.
3. Address range should be within 0—255. The address is unique in a loop.

Mode setting

Sensitivity Mode	dB/m	Application Environment
0	0.109	Clean Room
1	0.116	Hotel Room, Small Flat;
2	0.126	Office, Long Corridor
3	0.136	Ware House, Car Park

- ◇ Factory Setting: Sensitivity Mode 1
- ◇ The VG-6627 sensitivity mode can be set by Control Panel, please refer to the corresponding Manual for details.

Testing

Warning: Power is switched off before all devices are installed completely.

The detector must be tested after installation or regular maintenance.

- ✧ **Registration:** The fire alarm control panel will registers the detector on line to check if the address of the detectors mounted is the same address as that registered in the control panel.
- ✧ **Fire condition:** After registration, make detector under fire conditions by using Smoke generator to test whether the detector alarms normally and control panel displays its registered address.
- ✧ **Reset:** After testing, reset the detector through control panel.

Fault Finding

Detector Fault on Control Panel	Check wiring of Common base , no water no short-circuit and open circuit. Chenk the connection between detector and common base.
Nuisance alarm	The detector alarm frequently but there is no Fire and other unusual, then check whether the chamber in the detector is too dirty and needs to be cleaned Otherwise, the circuit may be broken.
Address Fault	Address is set incorrectly,Reset by VG-6532 Digital Programmer.

Cautions

- ✧ Dust cover on the detector shouldn't be removed between installation and acceptance test to avoid contamination.
- ✧ If the detector gives fault warning after a long operation, first check if the chamber in detector are too dirty, or the position is changed. At last, other faults should be considered.
- ✧ Fire alarm test requirement as specified in the applicable local codes,We suggest to test every 6 month.
- ✧ Please put on the dust cover if the room is decorated or wall-painted to avoid contamination.

Limited Warranty

We warrants that the product will be free of charge for repairing or replacing from defects in design, materials and workmanship during the warranty period. This warranty doesn't cover any product that is found to have been improperly installed or used in any way not in accordance with the instructions supplied with the product. Anybody, including the agents, distributors or employees, is not in the position to amend the contents of this warranty. Please contact your local distributor for products not covered by this warranty.